

# CDX-TREME Series UHF CB Antennas INSTALLATION GUIDE



Thank you for purchasing the CDX-TREME Antenna by RFI.

These antennas are specifically designed to reliably provide optimum range and performance in the 477 MHz Citizen Band in the harshest of environments.

## Frequency Bands:

476.425 - 477.4125

## Parts List:

Please check to ensure your antenna includes the following:

- Qty. 1 x Removable CDX-TREME series whip
- Qty. 1 x Spring assembly with 5m RG58 low loss cable terminated with FME(F) Jack Connector
- Qty. 1 x Accessories bag that includes one spacer washer one Allen key and one spare grub screw
- Qty. 1 x Adaptor: FME(male) Plug to UHF(male) Plug

## Notes:

1. Before installation, remove and dispose of the plastic ferrule protector at the bottom of the antenna whip by easing the grub screw (CDX5000-B High-Gain model only).
2. To ensure that your antenna base is securely mounted to the vehicle, it is recommended to tighten the mounting nut against the star washer to achieve the correct tightness, to provide a uniform clamping force and stress distribution in the joint to prevent failures. Routine checking of nut tightness is recommended for secure antenna mounting.

## Installation:

- The antenna can be mounted on a vehicle guard, boot, bull bar or other locations using an appropriate mounting bracket. Bull-bar mounting is ideal.
- When choosing a mounting location, it is best to ensure that the whole antenna (in particular, the fibreglass whip section itself) is as high as possible and as far away as practical from metallic obstructions (roof racks or vehicle pillars). This will minimise reflection or shadowing of the signal.
- For best result ensure there are no other antennas installed within 600mm of the antenna when installed to minimise signal interference.
- The antenna base is fitted with 5m of RG58 low loss coaxial cable - factory terminated with an FME(F) connector (jack) to simplify installation. In most cases no further cable termination should be required. A coaxial adaptor (FME plug to UHF plug) is also included.
- Your CDX-TREME Series may be supplied with the whip not installed. If this is the case, please remove (& keep) the protective cap from the top of the spring assembly, screw the antenna onto the spring assembly and tighten as necessary.
- Always ensure the grub screw is fully eased while screwing and unscrewing the antenna whip to and from the spring base so as not to cause any damage. Use the supplied Allen key to tighten the grub screw on the side of the whip to affix it to the spring assembly.

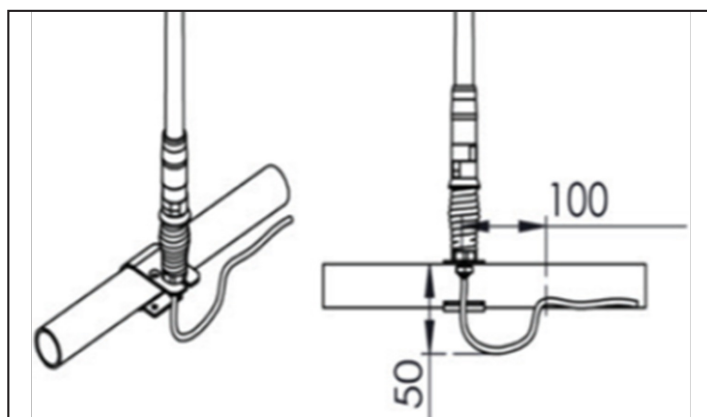

## Important:

When installing any spring-loaded antenna, it is important to allow enough loose cable at the base of the antenna for when the spring flexes.

A loop of 50mm before fixing the cable would be sufficient for CDX-TREME Series antennas (see image).